



**P/N 0-80457S & 0-80457SA**

***QUICK START***  
**CARBURETOR**  
**INSTALLATION INSTRUCTIONS**

Congratulations on your purchase of a new Holley carburetor built by craftsmen to exacting standards in our Bowling Green, Kentucky facility. Every carburetor is 100% wet-flow tested before it leaves our facility for “bolt on and go” performance.

Should you experience any problems or need parts assistance that this quick start manual or the complete installation manual does not address, please feel free to contact our technical service department at 1-866-GO-HOLLEY, (1-866-464-6553) Monday through Friday, 8 a.m. to 5 p.m. CST or log on to [www.holley.com](http://www.holley.com) for a database of technical information and online support.

## Before you get started - Do you really need a new carburetor or is there an underlying problem?

Holley Performance highly recommends the following items be checked and/or corrected prior to installation of your new carburetor to ensure optimum performance from your engine and your new Holley carburetor.

Many times a carburetor is looked at as the prime culprit or the main cause for a myriad of other engine-related difficulties that might exist. Therefore, it's best to check and verify the condition of the complete engine system before proceeding with any carburetor work. There should be no **vacuum leaks, the ignition timing should be properly set, and the engine should be in sound mechanical condition.**

Tuning or replacing the carburetor won't cure bad valves, leaky head gaskets, worn piston rings, or cracked and leaking vacuum lines.

Complaint/ Problem	Possible engine causes/ Checks to perform	Possible carburetor causes
<b>Backfires</b>	<ol style="list-style-type: none"> <li>1. Faulty EGR valve</li> <li>2. Bad ignition coil</li> <li>3. Fouled spark plugs or spark plug wires</li> <li>4. Improper ignition timing</li> <li>5. Valve timing off</li> <li>6. Valve train parts- broken or worn</li> </ol>	<ol style="list-style-type: none"> <li>1. Binding or sticking choke</li> <li>2. Accelerator pump not operating properly</li> <li>3. Clogged air or fuel filter</li> <li>4. Restricted bowl vents</li> <li>5. Vacuum leaks</li> </ol>
<b>Cuts out, Misses</b>	<ol style="list-style-type: none"> <li>1. Faulty spark plugs or spark plug wires</li> <li>2. Faulty ignition coil</li> <li>3. Restricted fuel filter or contaminated fuel</li> <li>4. Low fuel pressure</li> <li>5. Improper ignition timing</li> <li>6. Low Compression</li> <li>7. Bad distributor cap or rotor</li> <li>8. Valve train parts broken or worn</li> </ol>	<ol style="list-style-type: none"> <li>1. Dirty or plugged fuel inlet</li> <li>2. Contamination in fuel/ Old Gas</li> <li>3. Faulty power valve</li> <li>4. Restricted fuel bowl vents</li> <li>5. Improper fuel pressure</li> <li>6. Incorrect jetting</li> </ol>
<b>Floods</b>	<ol style="list-style-type: none"> <li>1. Incorrect fuel pressure</li> </ol>	<ol style="list-style-type: none"> <li>1. Float level incorrect</li> <li>2. Trash in the needle and seat</li> <li>3. No or dirty fuel filter</li> </ol>
<b>Hard Start - Cold</b>	<ol style="list-style-type: none"> <li>1. Vacuum leak or improper connections</li> <li>2. Faulty ignition wires or plugs</li> <li>3. Incorrect choke setting, faulty choke</li> <li>4. Sticky EGR valve</li> <li>5. Improper float level</li> <li>6. Clogged or dirty fuel filter</li> <li>7. Moisture in distributor cap</li> <li>8. Improper ignition timing</li> </ol>	<ol style="list-style-type: none"> <li>1. Low fuel in gas tank</li> <li>2. Binding or sticking choke</li> <li>3. No fuel in carburetor</li> <li>4. Engine or carburetor flooded</li> <li>5. Defective accelerator pump</li> </ol>
<b>Hard start - Hot</b>	<ol style="list-style-type: none"> <li>1. Vacuum leak or improper connections</li> <li>2. Faulty ignition wires or plugs</li> <li>3. Incorrect choke setting, faulty choke</li> <li>4. Carburetor flooding</li> <li>5. Clogged or dirty fuel filter</li> <li>6. Improper float level</li> <li>7. Weak battery or starter</li> <li>8. Engine overheating</li> <li>9. Improper ignition timing</li> </ol>	<ol style="list-style-type: none"> <li>1. Binding or sticking choke</li> <li>2. No fuel in carburetor</li> <li>3. Engine or carburetor flooded</li> <li>4. Leaking float bowl</li> <li>5. Fuel percolation</li> <li>6. Vapor lock</li> </ol>
<b>Hesitation, Sag, Stumble</b>	<ol style="list-style-type: none"> <li>1. Fuel contamination/ Old Gas</li> <li>2. Improper ignition timing</li> <li>3. Improper alternator voltage output</li> <li>4. Improper EGR valve operation</li> <li>5. Incorrect accelerator pump shot</li> </ol>	<ol style="list-style-type: none"> <li>1. Defective accelerator pump</li> <li>2. Incorrect accelerator pump nozzle</li> <li>3. Fuel level too low</li> <li>4. Carburetor loose on manifold/ Vacuum leak</li> <li>5. Incorrect power valve</li> <li>6. Secondaries opening too soon</li> </ol>
<b>Lack of power, Sluggish, or Spongy</b>	<ol style="list-style-type: none"> <li>1. Air filter dirty or plugged</li> <li>2. Improper ignition timing</li> <li>3. Restricted fuel filter</li> <li>4. Improper EGR valve operation</li> <li>5. Improper valve timing</li> <li>6. Low compression</li> <li>7. Restricted exhaust</li> </ol>	<ol style="list-style-type: none"> <li>1. Throttle not opening all the way</li> <li>2. Dirty or plugged fuel inlet</li> <li>3. Faulty or incorrect power valve</li> <li>4. Float level too low</li> <li>5. Float or needle and seat sticking</li> <li>6. Incorrect or plugged main jets</li> <li>7. Secondaries not opening correctly</li> </ol>

## Installation:

**NOTE:** Please see the enclosed instruction manual for complete removal, installation, and tuning instructions.

1. Place the new carburetor flange gasket, provided with the carburetor, in the proper position on the intake manifold.
2. Place the carburetor on top of the flange gasket on the manifold. Install the hold down nuts and snug down progressively in a "criss-cross" pattern (60-80 in./lbs.), as shown in **Figure 1**.
3. Reconnect the throttle and transmission kick-down linkage. Be sure to check for any binding conditions and correct before proceeding. **See main manual for detailed instructions on hooking up transmission linkages.**
4. Reconnect the appropriate vacuum hoses to the carburetor. **Be sure to plug any vacuum sources not used (Figures 2 and 3).**

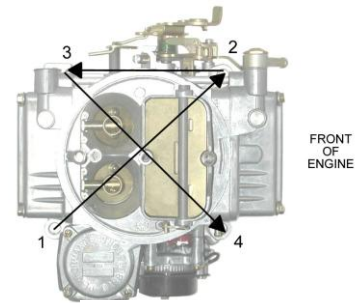

Figure 1

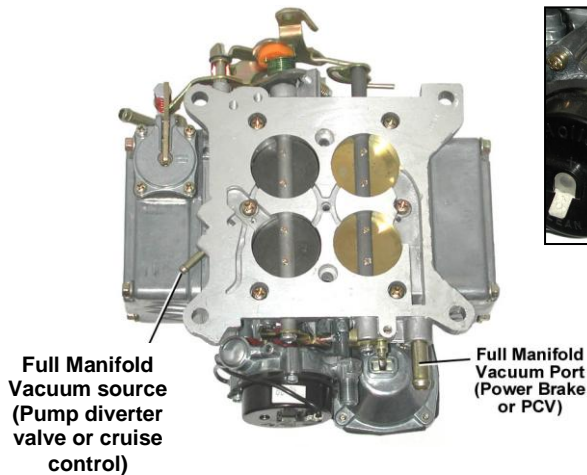

Figure 2

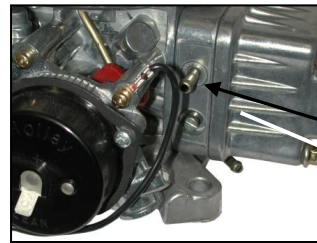

Figure 3

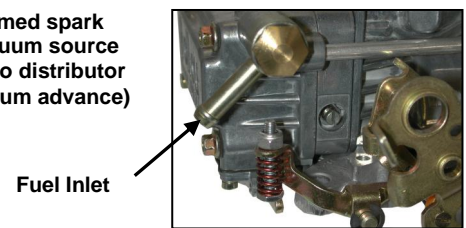

Figure 4

5. Connect the fuel feed line along with an appropriate inline filter (**Figure 4**).
6. Connect the electric choke lead (supplied) to the positive terminal of the choke cap. Connect the other end to an **ignition-activated 12 volt** power source. Do not hook to the positive side of the ignition coil. **Hookup of this wire is NOT optional (Figure 5).**



### Mr. Carb Tune's Helpful Hints:

**Tips on hooking up the Electric Choke 12V Power Wire.** This wire must be hooked up to a 12 volt power supply that is switched on and off with the ignition switch for the choke to function properly. Proper places to get 12 volt, switched power include: fuse panel, ignition switch (must install 10 amp fuse), or accessory power terminals. Do not tap into any power source connected to the ignition coil or distributor, as this may cause misfiring and starting problems. Also please be aware that most O.E. choke connections are not a full 12 volts.

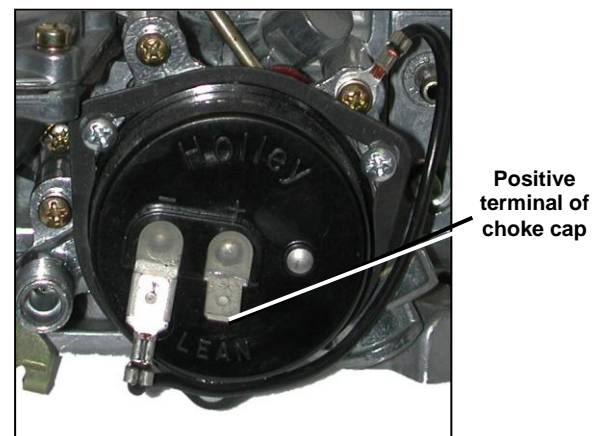
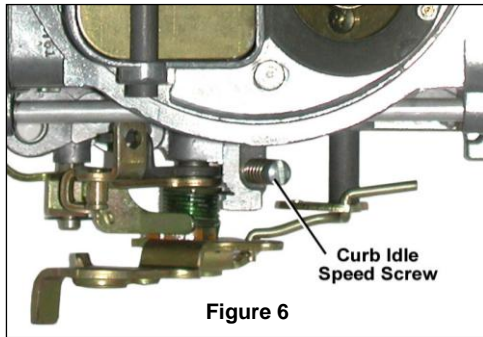

Figure 5

7. Recheck all connections and bolts for tightness and/or leaks.
8. Start vehicle and recheck for leaks.
9. Start the vehicle and let it warm up to operating temperature.

## Installation Continued:

10. Adjust the curb idle speed (Figure 6).



### Mr. Carb Tune's Helpful Hints:

In most cases the curb idle screw is the only adjustment you should make. Place the transmission in park or neutral. (MAKE SURE THE PARKING BRAKE IS ON OR THE WHEELS ARE CHOCKED.) Adjust the screw clockwise to increase RPM and counter-clockwise to decrease engine RPM at idle.



11. Adjust the idle fuel mixture, if necessary (Figures 7 and 8).

### Mr. Carb Tune's Helpful Hints:

**THE IDLE MIXTURE IS FACTORY SET.** In the unlikely event that your engine requires a slightly different mixture, follow these instructions: The idle system supplies the air/fuel mixture to operate the engine at idle and low speeds. The idle mixture screws are located on the sides of the primary metering block. Turning the screws clockwise will "lean" the idle system. Turning the screws counter-clockwise will "richen" the idle system. The initial adjustment is made by turning the mixture screws in a clockwise direction until they lightly bottom. Back them both off 1 1/2 turns. Then, turn the needles inward 1/8 turn at a time until the engine begins to run worse or you see a 100 RPM drop on your tachometer. Then, turn them out 1/8 turn each until the engine smooths out (or reaches your desired RPM). **Both idle mixture needles should be adjusted an even number of turns.**



Figure 7

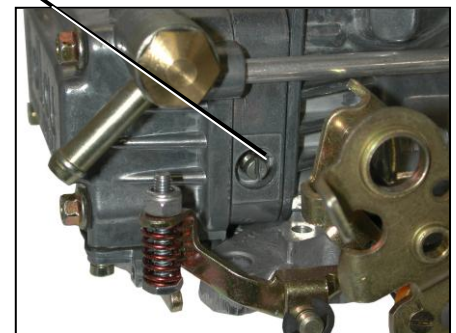

Figure 8

12. Further adjustments are not needed in most cases, but if you should need to perform any of the following, these references should help:
- Fast idle when cold (See page 9 of installation manual)
  - Choke adjustment (See page 9 of installation manual)
  - Vacuum secondary (See page 12 of installation manual)

If you experience any problems with the installation or tuning of this unit,

# STOP!

DO NOT RETURN IT TO THE PLACE OF PURCHASE without FIRST calling Holley toll free at 1-866-GO-HOLLEY.