



## HOLLEY VOLUMAX™ FUEL REGULATOR

# VOLUMAX™

## INSTALLATION INSTRUCTIONS

**NOTE:** To preserve warranty, please read and follow these instructions thoroughly and completely, before and during installation.

These instructions are designed for use with the Volumax high performance fuel regulators and are **NOT** recommended for fuel injected vehicles or for marine use.

There are two types of Volumax regulators. P/N 12-704 is a two port design that should be used on single carburetor installations. When using a single feed carburetor, one of the regulator outlet ports must be plugged. P/N 12-707 is a four port design that should be used on dual carburetor, dual feed installations.

### INSTALLATION INSTRUCTIONS

1. Using the bracket supplied, mount the regulator as close to the carburetor as possible, taking care to minimize the exposure to heat sources. **DO NOT** mount the regulator on the exhaust manifold or any extremely hot surface. Be sure to select a location where the fuel lines are also kept away from heat and moving parts.
2. Connect the fuel lines from the pump to the regulator and from the regulator to the carburetor. Note that the Volumax regulators are supplied with AN style fuel fittings. The four port regulator (P/N 12-707) uses a special type of o-ring AN fitting, therefore AN braided fuel lines must be used.

**CAUTION: DO NOT overtighten fuel lines or fittings, because the aluminum regulator body may crack.**

3. Start the engine and check for fuel leaks.
4. The fuel pressure of the Volumax regulators is pre-set at 6 psi and may be readjusted for individual requirements. To increase the pressure, loosen the locknut and turn the adjustment screw clockwise, counter-clockwise will lower the pressure. Turning the adjustment all the way down will result in excessive pressure and cause carburetor flooding. Always use a fuel pressure gauge, such as Holley P/N 26-500, between the regulator and carburetor when setting fuel pressure.

**NOTE:** Holley Volumax fuel pumps have a fuel return line port. This return line back to the fuel tank **MUST** be used or excessive fuel pressure will result.

### CLEANING THE REGULATOR

1. Loosen the hex nut on top of the regulator and back the adjusting screw out all the way to relieve tension on the diaphragm spring. See Figure 1.
2. Remove the four screws holding the regulator cover on. The diaphragm, spring, and spring guide will fall out.
3. Use spray type carburetor cleaner to clean the cover and the regulator body. Thoroughly spray into the ports as well as into the check ball seat area while depressing the check ball. **NOTE:** The brass seat assembly is pressed in and should not be removed.
4. Blow the cover and body dry with compressed air and reassemble following the diagram below.
5. Be sure to readjust fuel pressure with the adjusting screw after reinstalling in your vehicle.

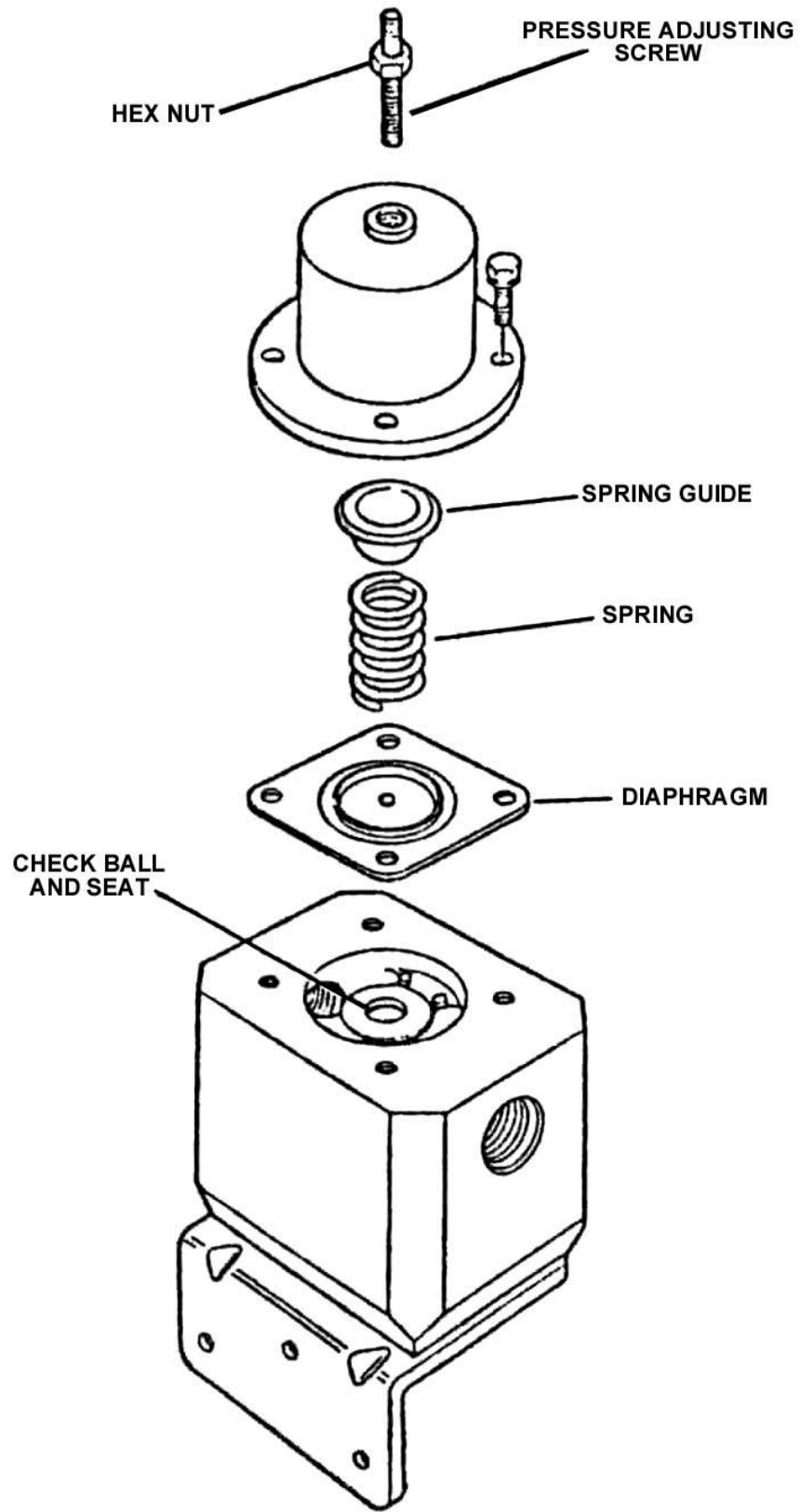

Figure 1