



THE PERFORMANCE EXHAUST COMPANY™

SUPER STREET DUAL KITS

51525FLT Header Dual Kit 52525FLT Manifold Dual Kit

1973-1987 Chevrolet/GMC ¼, ½, 1 ton Pickups and Suburban 4WD with 350-400 CID Engines.

Will not fit vehicles with wheelbases longer than 131.5"

NOTE: PART NUMBER 51525 HEADER DUALS: THIS SYSTEM WAS DESIGNED TO FIT WITH **FLOWTECH**® HEADERS #11500 AND #31500. IF THIS KIT IS TO BE INSTALLED WITH HEADERS OTHER THAN THESE NUMBERS, SOME MODIFICATION MAY BE NECESSARY. **FLOWTECH** DOES NOT ASSUME RESPONSIBILITY FOR FIT OR PERFORMANCE.

NOTE: THIS PERFORMANCE EXHAUST SYSTEM IS NOT SUPPLIED WITH MUFFLERS OR MUFFLER U-CLAMPS. FOR MAXIMUM PERFORMANCE, WE RECOMMEND **FLOWTECH** RAPTOR TURBO MUFFLERS PART #50051 OR AN EQUIVALENT 2¼" INLET AND OUTLET SINGLE OFFSET TURBO MUFFLER.

THIS DEVICE IS NOT LEGAL FOR USE ON POLLUTION-CONTROLLED MOTOR VEHICLES. IT IS INTENDED FOR USE ON VEHICLES THAT WILL NEVER BE DRIVEN UPON A HIGHWAY. IF YOU HAVE ANY QUESTIONS CONCERNING HOW THIS EFFECTS YOU AND YOUR VEHICLE, CONTACT THE DEALER FROM WHOM YOU PURCHASED THIS DEVICE OR CONTACT THE FACTORY DIRECT.

We realize that you had many choices when you made your purchase, we thank you for purchasing **FLOWTECH**. At **FLOWTECH** we put our many years of performance exhaust experience into every product we build. We feel and know you will agree, **FLOWTECH** products are the best you can buy at any price.

If this is your first time installing an exhaust product, it may be time consuming. While not complex, stick with it. As soon as you start your engine, the reward of additional horsepower and performance will be well worth your efforts.

READ THESE INSTRUCTIONS CAREFULLY BEFORE STARTING:

For the ease of installation, your vehicle must be raised a minimum of 24". Warning: Should you decide to install any exhaust products yourself, be warned that the original equipment jack that came with the vehicle is intended for emergency use only. The use of a frame jack, in conjunction with a floor jack as the main support, is highly recommended to minimize the accidental dropping of a vehicle while the installation proceeds. Never go under any vehicle that is supported by a bumper jack!

INSTALLATION INSTRUCTIONS

1. Remove the existing header crossover and exhaust system. Save the gaskets and sleeves from the headpipes. Remove the old pipe hangers.
2. Install the new headpipes reusing the gaskets and sleeves mentioned above. Hand tighten only, as to hold pipe in place. Install the front and rear section headpipe, (On header duals #51525 install header extensions using 2½" U-clamps). Do not tighten.
3. Install the mufflers on the headpipes (or header extensions) as in illustration. Puts U-clamps in place, but do not tighten. Rotate the headpipes and mufflers to clear the transfer case, drive shaft, and frame. Over the front or rear of the muffler, you will find a cross-member or body mount that can be drilled to accept a 5/16" bolt and rubber hanger.
4. Models with 117.5" and 131.5" wheel bases, it will be necessary to install the front tailpipe extensions (part number 51525FTE). On the 117.5" wheelbase, cut approximately 14" off the front of pipe, (see illustration).
5. Install the tailpipe sections with the hump in the pipe up over the rear axle housing to allow for maximum suspension clearance.
6. As the tailpipe exit under the frame to the rear of the vehicle, locate a hole in this area to mount the 90 degree metal bracket and hanger to. It may be necessary to drill a new hole a mentioned in #3 above. See illustration for desired pipe location. Cut the end of the tailpipes for desired length.
7. Make sure all components of the exhaust system clear all frame members, hoses, suspension, and brake lines.
8. Starting from the front of the vehicle, tighten all U-clamps and hangers, making sure that all parts are clear and will not leak or rattle.

WHEN YOU HAVE FINISHED INSTALLING YOUR **FLOWTECH SUPER STREET DUAL KIT** TAKE YOUR VEHICLE FOR A ROAD TEST. LISTEN CAREFULLY FOR ANY EXHAUST LEAKS OR OTHER STRANGE NOISES AND MAKE CORRECTIONS. WHEN THE VEHICLE HAS BEEN DRIVEN FOR A FEW DAYS, RETIGHTEN THE BOLTS.

SUPER STREET HEADER DUAL KIT #51525 - Parts List

Component	Description	Qty	Reference
51525LHE	Left Header Extension	1	E
51525RHE	Right Header Extension	1	F
51525LTP-A	Left Tailpipe - section "A"	1	G
51525LTP-B	Left Tailpipe - section "B"	1	G-B
51525RTP-A	Right Tailpipe - section "A"	1	H
51525RTP-B	Right Tailpipe - section "B"	1	H-B
51525FTE	Front Tailpipe Extension	2	J
CL10004TNN	2¼" U-clamps	6	
CL10008TNN	2½" U-clamps	4	
H-16	Tailpipe Hanger	4	
UN-3	Hanger Bracket	2	
5/16" x 1-1/4"	Bolts	8	
5/16"	Nuts	8	
5/16"	Lock Washers	8	
FW10	Fender Washers	4	
BRL 4	Brackets	2	

TYPICAL VIEW - CHEVY/GMC PU/SUBURBAN

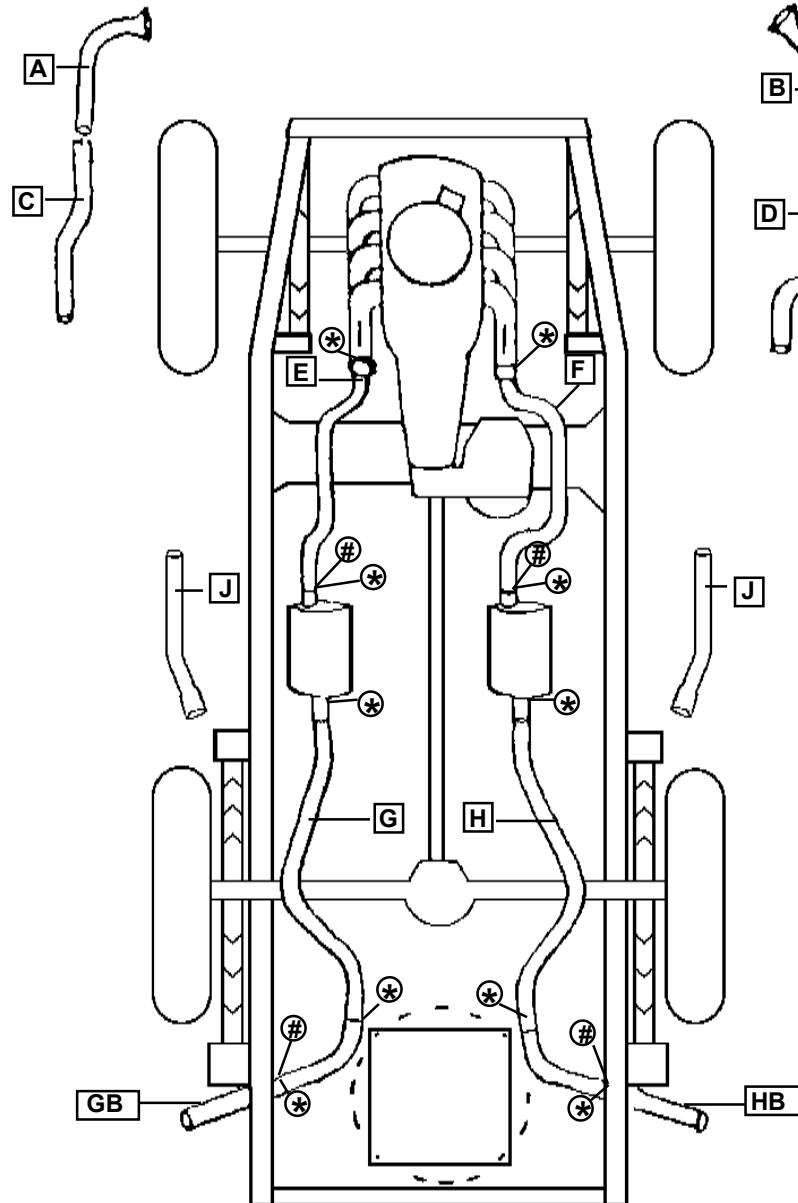

* - CLAMP LOCATION

- HANGER LOCATION

SUPER STREET MANIFOLD DUAL KIT #52525 - Parts List

Component	Description	Qty	Reference
52525LMH	Left Manifold Headpipe	1	A
52525RMH	Right Manifold Headpipe	1	B
52525LRH	Left Rear Section Headpipe	1	C
52525RRH	Right Rear Section Headpipe	1	D
51525LTP-A	Left Tailpipe - section "A"	1	G
51525LTP-B	Left Tailpipe - section "B"	1	G-B
51525RTP-A	Right Tailpipe - section "A"	1	H
51525RTP-B	Right Tailpipe - section "B"	1	H-B
51525FTE	Front Tailpipe Extension	2	J
CL10004TNN	2 1/4" U-clamps	6	
CL10008TNN	2 1/2" U-clamps	4	
H-16	Tailpipe Hanger	4	
UN-3	Hanger Bracket	2	
5/16" x 1-1/4"	Bolts	8	
5/16"	Nuts	8	
5/16"	Lock Washers	8	
FW10	Fender Washers	4	
BRL 4	Brackets	2	

LIMITATION OF LIABILITY - DISCLAIMER: THE REGULATION OF EMISSIONS PRODUCTION, NOISE LEVELS, AND SAFETY STANDARDS IS UNDERTAKEN BY THE FEDERAL GOVERNMENT, EACH OF THE FIFTY STATE LEGISLATURES AND BY MANY LOCAL MUNICIPALITIES, TOWNS, AND COUNTIES.

FLOWTECH MAKES NO WARRANTIES OF MERCHANTABILITY, OF FITNESS FOR PARTICULAR PURPOSE, OR THAT ITS PRODUCTS ARE APPROVED FOR GENERAL USE, OR THAT ITS PRODUCTS COMPLY WITH LAWS, REGULATIONS, OR ORDINANCES IN THE STATES WHERE THEY MAY BE SOLD TO THE ULTIMATE PURCHASER, THE CONSUMER. UNLESS EXPRESSLY STATED TO THE CONTRARY IN THE FLOWTECH CATALOG, INSTRUCTION SHEET, OR PRICE LIST, THE ENTIRE RISK AS TO THE CONFORMITY OF ANY COMPANY PRODUCT IN ANY SUCH STATE AND AS TO REPAIR SHOULD THE PRODUCT PROVE TO BE DEFECTIVE OR NONCONFORMING, IS ON THE RETAIL PURCHASER, THE BUYER, THE ULTIMATE CONSUMER, OF SUCH PRODUCT AND IT IS NOT UPON THE SELLER, DISTRIBUTOR, OR MANUFACTURER.

IN THE CONNECTION, RETAIL PURCHASER, THE BUYER, THE ULTIMATE CONSUMER ASSUMES THE BURDEN OF THE ENTIRE COST OF ANY AND ALL NECESSARY SERVICE, ALTERATIONS, OR REPAIR.

THE FOREGOING STATEMENT LIMITS THE LIABILITY OF THE MANUFACTURER. CALIFORNIA VEHICLE CODE SECTIONS 27156 AND 38391 PROHIBIT THE ADVERTISING, OFFERING FOR "SALE, OR INSTALLATION OF ANY DEVICE WHICH MODIFIES A VEHICLE'S EMISSIONS CONTROL SYSTEM UNLESS EXEMPTED. UNLESS OTHERWISE NOTED, FLOWTECH EXHAUST PRODUCTS HAVE NOT RECEIVED AN EXEMPTION FROM THESE CODE SECTIONS AND ARE NOT LEGAL FOR SALE OR USE IN CALIFORNIA ON VEHICLES ORIGINALLY EQUIPPED WITH CATALYTIC CONVERTERS. IT IS ILLEGAL, EXCEPT FOR RACING VEHICLES THAT WILL NEVER BE DRIVEN UPON A HIGHWAY.

FLOWTECH
by **Holley**

THE PERFORMANCE EXHAUST COMPANY™
1801 Russellville Road, Bowling Green, KY 42102
Phone: 270-781-9741 Fax: 270-781-9772