

# TRUCK TOOBS™

COMPLETE BOLT-ON CATBACK SYSTEMS FOR  
TRUCK TRUCKS, SUPER TRUCKS, AND SPORT TRUCKS

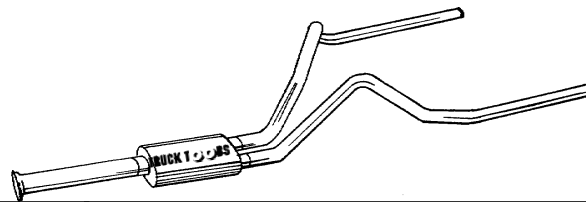

## FLOW TECH™

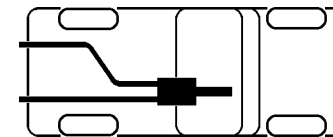

P/N	YR	MAKE	MODEL	ENGINE	TYPE
62400	87-96	FORD	F150/250 STD CAB SHORT BED	4.9L,302,351	2/4 WD
62402	87-96	FORD	F150/250 EXT CAB SHORT BED	4.9L,302,351	2/4WD

WILL NOT FIT 250HD WITH ONE CONVERTER

### READ THESE INSTRUCTIONS CAREFULLY BEFORE STARTING:

For ease of installation, your vehicle must be raised a minimum of 36". **Warning:** Should you decide to install any exhaust yourself, be warned that the original equipment jack that came with the vehicle is intended for emergency use only. The use of a frame jack, in conjunction with a floor jack as the main support, is highly recommended to minimize the accidental dropping of a vehicle while the installation proceeds. Never go under any vehicle that is supported by only a bumper jack!

### REMOVE THE OLD EXHAUST SYSTEM AFTER THE CATALYTIC CONVERTER FROM VEHICLE.

1. Starting at the catalytic converter, leave all rubber grommets in place. If the mounting bracket for the intermediate pipe is located on the side of the frame, completely unbolt the bracket from the frame to ease in removal.
2. Save all factory mounting hardware and fasteners.
3. To ease in the removal of the old exhaust system, it may be necessary to cut the tailpipes from the muffler.

### INSTALLATION OF YOUR NEW TRUCKTOOBS™ CATBACK EXHAUST SYSTEM.

1. Lay the system out on the ground in the order of installation.
2. Install the intermediate pipe to the catalytic converter.
3. Slide the muffler onto the intermediate pipe. Align the hanger in front of the muffler into the rubber hanger. Install the 3" clamp on the front of the muffler. *FINGER TIGHTEN ONLY.*
4. Slip the passenger side intermediate tailpipe into the rear of muffler and clamp with 2½" muffler clamps. *FINGER TIGHTEN ONLY.*
5. Slip the passenger side end tailpipe into the intermediate pipe using a 2½" muffler clamp. *FINGER TIGHTEN ONLY.* Slide the hanger into the overhead rubber grommet. Bolt into position, using factory fasteners. *FINGER TIGHTEN ONLY.*
6. Slip the driver's side intermediate tailpipe into the rear of the muffler.
7. Slip the driver's side end tailpipe into the intermediate pipe using a 2½" muffler clamp. *FINGER TIGHTEN ONLY.* Mount with the bracket provided. See Illustration "A".
8. The rear driver's side bracket mounts to an existing (on most trucks) hole on the frame.
9. Install all the clamps. *FINGER TIGHTEN ONLY.*
10. Make sure that the muffler is in a horizontal position. At this time, tighten all bolts and muffler clamps between the muffler and the converter.
11. Align the tailpipes. Make the necessary adjustments to provide maximum clearance for shocks, spare tire, and body parts.
12. Firmly tighten all remaining clamps and bolts.

**INSTALLATION NOTE:** Your vehicle's exhaust system gets hot enough to melt rubber and blister paint. Inspect your installation to be sure there is proper clearance to all brake lines, fuel lines, tires, and body panels.

When you have finished installing your TRUCKTOOB™ Catback Exhaust System, take the vehicle for a road test. Listen carefully for any exhaust leaks or other strange noises and make corrections. When the vehicle has been driven for a few days, retighten the bolts and clamps.

HOW DID WE DO? YOUR QUESTIONS AND INPUT ARE ALWAYS WELCOME AT FLOWTECH®. OUR TECHNICAL SERVICES DEPARTMENT IS OPEN MONDAY THROUGH FRIDAY, DURING THE HOURS OF 8:30AM UNTIL 4:30PM CENTRAL TIME. WE CAN BE REACHED AT:

## FLOW TECH® by Holley®

THE PERFORMANCE EXHAUST COMPANY™  
1801 Russellville Road, Bowling Green, KY 42101  
Phone: 270-781-9741 Fax: 270-781-9772

### ILLUSTRATION "A"

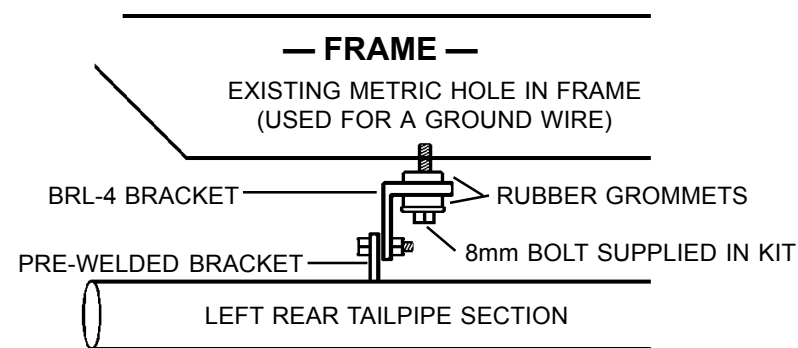

62400 03/14/01

**ILLUSTRATION "B"**

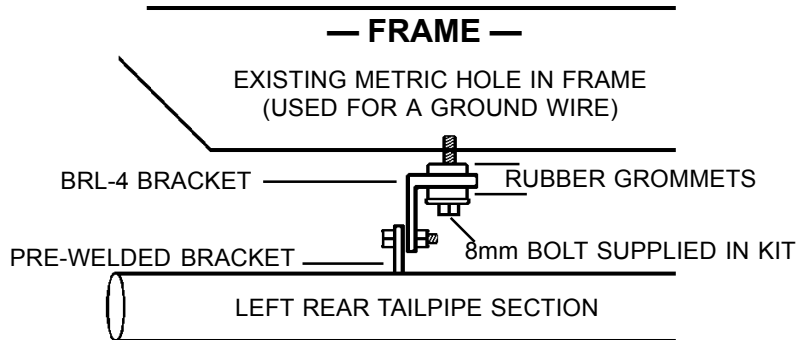

HOW DID WE DO? YOUR QUESTIONS AND INPUT ARE ALWAYS WELCOME AT *FLOWTECH*® OUR TECHNICAL SERVICES DEPARTMENT IS OPEN MONDAY THROUGH FRIDAY, DURING THE HOURS OF 8:30AM UNTIL 4:30PM CENTRAL TIME. WE CAN BE REACHED AT:

***FLOW* TECH**  
by **Holley**

THE PERFORMANCE EXHAUST COMPANY™  
1801 Russellville Road, Bowling Green, KY 42101  
Phone: 270-781-9741 Fax: 270-781-9772

**LIMITATION OF LIABILITY - DISCLAIMER:** THE REGULATION OF EMISSIONS PRODUCTION, NOISE LEVELS, AND SAFETY STANDARDS IS UNDERTAKEN BY THE FEDERAL GOVERNMENT, EACH OF THE FIFTY STATE LEGISLATURES AND BY MANY LOCAL MUNICIPALITIES, TOWNS, AND COUNTIES.

*FLOWTECH*® MAKES NO WARRANTIES OF MERCHANTABILITY, OF FITNESS FOR PARTICULAR PURPOSE. OR THAT ITS PRODUCTS ARE APPROVED FOR GENERAL USE, OR THAT ITS PRODUCTS COMPLY WITH LAWS, REGULATIONS, OR ORDINANCES IN THE STATES WHERE THEY MAY BE SOLD TO THE ULTIMATE PURCHASER, THE CONSUMER.

UNLESS EXPRESSLY STATED TO THE CONTRARY IN THE ACCOMPANYING CATALOG, INSTRUCTION SHEET, OR PRICE LIST, THE ENTIRE RISK AS TO THE CONFORMITY OF ANY COMPANY PRODUCT IN ANY SUCH STATE AND AS TO REPAIR SHOULD THE PRODUCT PROVE TO BE DEFECTIVE OR NONCONFORMING, IS ON THE RETAIL PURCHASER, THE BUYER, THE ULTIMATE CONSUMER, OF SUCH PRODUCT AND IT IS NOT UPON THE SELLER, DISTRIBUTOR, OR MANUFACTURER.

IN THE CONNECTION, RETAIL PURCHASER, THE BUYER, THE ULTIMATE CONSUMER ASSUMES THE BURDEN OF THE ENTIRE COST OF ANY AND ALL NECESSARY SERVICE, ALTERATIONS, OR REPAIR.