

TRUCK TOOBTM

COMPLETE BOLT-ON CATBACK SYSTEMS FOR
TRUCK TRUCKS, SUPER TRUCKS AND SPORT TRUCKS

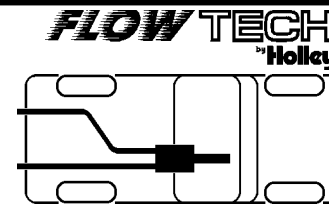
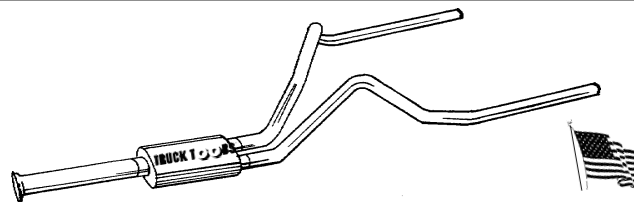

P/N	YR	MAKE	MODEL	ENGINE	TYPE
62800	94-97	DODGE RAM PU	STD/EXT CAB S/L BED	6CYL,318,360	2/4 WD

NOTE: THIS SYSTEM IS DESIGNED AS A SAME-SIDE EXIT EXHAUST IN ORDER TO RETAIN THE FACTORY SPARE TIRE LOCATION.

READ THESE INSTRUCTIONS CAREFULLY BEFORE STARTING:

For the ease of installation, your vehicle must be raised a minimum of 36". **WARNING:** Should you decide to install any exhaust yourself, be warned that the original equipment jack that came with the vehicle is intended for emergency use only. The use of a frame jack, in conjunction with a floor jack as the main support, is highly recommended to minimize the accidental dropping of a vehicle while the installation proceeds. Never go under any vehicle that is supported by a bumper jack!

REMOVE THE OLD EXHAUST SYSTEM AFTER THE CATALYTIC CONVERTER FROM VEHICLE.

1. Starting at the catalytic converter, leave all the rubber grommets in place. If the mounting bracket for the intermediate pipe is located on the side of the frame, completely unbolt the bracket from the frame to ease removal.
2. Save all factory mounting hardware and fasteners.
3. To ease removal of old exhaust system, it may be necessary to cut the tailpipes from the muffler.

INSTALLATION OF YOUR NEW TRUCKTOOBTM CATBACK EXHAUST SYSTEM.

1. Lay the system out on the ground in the order of installation.
2. Install the intermediate pipe to the catalytic converter.
3. Slide the muffler onto the intermediate pipe. Align the hanger in front of the muffler into the rubber hanger. Install the 3" clamp on the front of the muffler. *FINGER TIGHTEN ONLY.*
4. Slip the passenger side intermediate tailpipe into the rear of the muffler and clamp with 2½" muffler clamps. *FINGER TIGHTEN ONLY.*
5. Slip the passenger side end tailpipe into the intermediate pipe using a 2½" muffler clamp. *FINGER TIGHTEN ONLY.* Slide the hanger into the overhead rubber grommet. Bolt into position using the factory fasteners. *FINGER TIGHTEN ONLY.*
6. Slip the drivers side intermediate tailpipe into the rear of muffler.
7. Slip the drivers side end tailpipe into the intermediate pipe using a 2½" muffler clamp. *FINGER TIGHTEN ONLY.*
8. The rear drivers side bracket mounts to an existing (on most trucks) hole on the frame.
9. Install all clamps. *FINGER TIGHTEN ONLY.*
10. Make sure that the muffler is in a horizontal position. At this time, tighten all bolts and muffler clamps between the muffler and converter.
11. Align the tailpipes. Make the necessary adjustments to provide maximum clearance for the shocks, spare tire, and body parts.
12. Firmly tighten all the remaining clamps and bolts.

INSTALLATION NOTE: Your vehicle's exhaust system gets hot enough to melt rubber and blister paint. Inspect your installation to be sure there is proper clearance to all brake line, fuel lines, tires, and body panels.

When you have finished installing your TrucktoobTM Catback Exhaust System, take the vehicle for a road test. Listen carefully for any exhaust leaks or other strange noises and make corrections. When the vehicle has been driven for a few days, retighten the bolts and clamps.

ILLUSTRATION "A"

INSTALL STOCK HANGER IN THIS POSITION

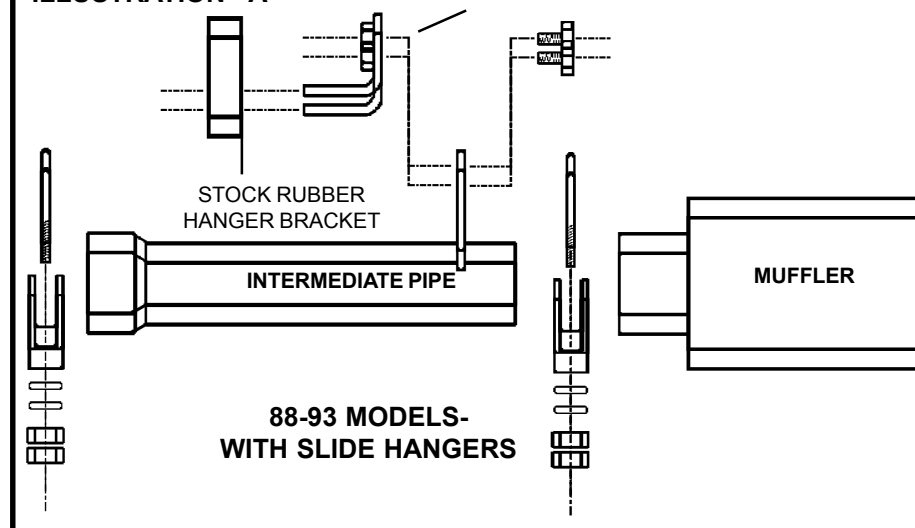

88-93 MODELS-
WITH SLIDE HANGERS

HOW DID WE DO? YOUR QUESTIONS AND INPUT ARE ALWAYS WELCOME AT FLOWTECH[®]. OUR TECHNICAL SERVICES DEPARTMENT IS OPEN MONDAY THROUGH FRIDAY, DURING THE HOURS OF 8:30AM UNTIL 4:30PM CENTRAL TIME. WE CAN BE REACHED AT:

FLOW TECH[®]
by **Holley[®]**

THE PERFORMANCE EXHAUST COMPANYTM
1801 Russellville Road, Bowling Green, KY 42101
Phone: 270-781-9741 Fax: 270-781-9772

ILLUSTRATION "B"

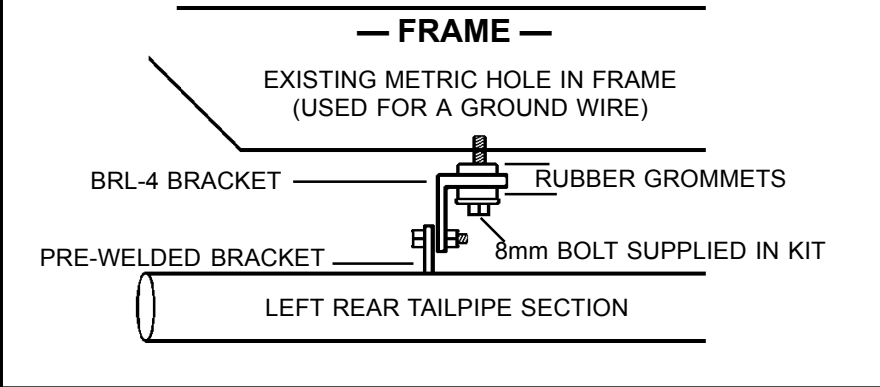

HOW DID WE DO? YOUR QUESTIONS AND INPUT ARE ALWAYS WELCOME AT *FLOWTECH*®. OUR TECHNICAL SERVICES DEPARTMENT IS OPEN MONDAY THROUGH FRIDAY, DURING THE HOURS OF 8:30AM UNTIL 4:30PM CENTRAL TIME. WE CAN BE REACHED AT:



THE PERFORMANCE EXHAUST COMPANY™
1801 Russellville Road, Bowling Green, KY 42101
Phone: 270-781-9741 Fax: 270-781-9772

LIMITATION OF LIABILITY - DISCLAIMER: THE REGULATION OF EMISSIONS PRODUCTION, NOISE LEVELS, AND SAFETY STANDARDS IS UNDERTAKEN BY THE FEDERAL GOVERNMENT, EACH OF THE FIFTY STATE LEGISLATURES, AND BY MANY LOCAL MUNICIPALITIES, TOWNS, AND COUNTIES.

FLOWTECH® MAKES NO WARRANTIES OF MERCHANTABILITY, OF FITNESS FOR PARTICULAR PURPOSE, OR THAT ITS PRODUCTS ARE APPROVED FOR GENERAL USE, OR THAT ITS PRODUCTS COMPLY WITH LAWS, REGULATIONS, OR ORDINANCES IN THE STATES WHERE THEY MAY BE SOLD TO THE ULTIMATE PURCHASER, THE CONSUMER.

UNLESS EXPRESSLY STATED TO THE CONTRARY IN THE ACCOMPANYING CATALOG, INSTRUCTION SHEET, OR PRICE LIST, THE ENTIRE RISK AS TO THE CONFORMITY OF ANY COMPANY PRODUCT IN ANY SUCH STATE AND AS TO REPAIR SHOULD THE PRODUCT PROVE TO BE DEFECTIVE OR NONCONFORMING, IS ON THE RETAIL PURCHASER, THE BUYER, THE ULTIMATE CONSUMER, OF SUCH PRODUCT AND IT IS NOT UPON THE SELLER, DISTRIBUTOR, OR MANUFACTURER.

IN THE CONNECTION, RETAIL PURCHASER, THE BUYER, THE ULTIMATE CONSUMER ASSUMES THE BURDEN OF THE ENTIRE COST OF ANY AND ALL NECESSARY SERVICE, ALTERATIONS, OR REPAIR.