

VALVE TRAIN

VALVE SPRING TECHNICAL INFORMATION

VALVE SPRING TECHNICAL INFORMATION

CAMS

How To Get The Most Out Of Your Lunati Valve Springs

• Valve Spring Fitment

Valve Spring Pocket Clearance

Valve spring pocket clearance is the gap between the inside diameter of the valve spring pocket (or cup, if used) and the outside diameter of the valve spring.

- Too much clearance will result in the spring “dancing” around in the head, which “beats up” the spring mounting surface and the spring itself. If this is the case, a spring cup may be used. Additional machining of the spring pocket may be required to accept the spring cup.
- Not enough clearance will bind the spring in the pocket, overstressing the bottom coil by limiting its movement and not allowing the spring to “grow”. This will cause the bottom coil to wear against the head and/or prematurely fail. Machine the valve pocket using a Spring Seat Cutter if not enough clearance exists.

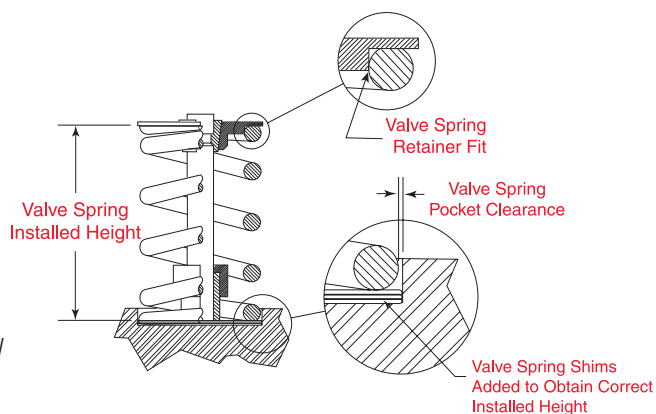

Valve Spring Retainer Fit The valve spring retainer should fit the valve spring being used. A slightly snug fit is acceptable, however a fit that is too tight can overstress the top coil, and cause it to fail. A fit that is too loose can lead to spring “dancing.”

Valve Spring Installed Height The installed height of the valve spring is the distance between the valve pocket (or cup, or shims) and the outer edge of the spring retainer (which is the height of the valve spring) when the valve is closed. To check installed height, follow the following procedure:

1. Install the valve in the guide.
2. Install the retainer and valve locks.
3. Install all spring cups and/or valve spring shims (basically, everything except the valve spring).
4. Hold the valve closed by pulling the retainer up tightly against the valve locks.
5. Measure the distance between the outside edge of the valve spring retainer and the spring seat. A snap gage or a height micrometer should be used.
6. Check the distance against what is recommended on the camshaft specification card. An installed height of ± 0.020 is acceptable.
7. If the installed height is not within 0.020 ”, either machining of the valve pocket, or removal/installation of valve spring shims is necessary.
8. Repeat this procedure for the rest of the valves.

VALVE TRAIN

PISTONS

RODS

CRANKS

ENGINE KITS

APPAREL



VALVE SPRING TECHNICAL INFORMATION

Spring Retainer to Valve Seal Clearance

The distance between the innermost step on the valve spring retainer and the valve guide must be 0.090" larger than the maximum valve lift of the camshaft.

Measure the distance between the top of the valve seal to the bottom of the valve spring retainer. After adding 0.090" to your measurement, it should still be larger than the maximum valve lift of the camshaft. If not, machining of the valve guide is necessary for adequate clearance.

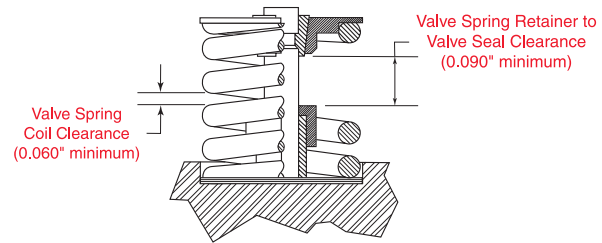

Valve Spring Coil Clearance

Coil clearance is the distance between the valve spring coils when the valve is at its maximum lift (fully open). A minimum of 0.060" must exist between the coils at maximum lift. Coil bind is when the valve spring is compressed fully to the point that all of the coils are "stacked up" on top of each other. For high RPM applications, .100 is recommended. Coil bind is a catastrophic condition that will result in valve train failure.

Disassemble each spring (if multiple springs are employed at each valve). Check all the springs (both inner, and outer springs) if there is not 0.060"- 0.100" minimum of clearance between the coils, the solutions are: the valve retainer, the valve locks, the valve, or the spring must be changed; the spring pocket must be machined. Keep in mind that these modifications will change the valve spring installed height.

Retainer to Rocker Arm Clearance

When installing the rocker arms, check to see that the inside of the rocker arms clear the spring retainers. Many rocker arms have a "relief" to accommodate large valve spring retainers.

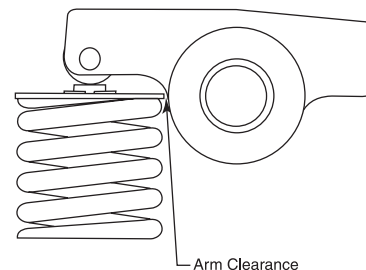

• Valve Spring Run-In

Each set of Lunati valve springs are hand-selected to keep load variations below +/- 10% of the next. However, it is important to "run in" your new valve springs at low RPM using the following procedure:

1. Start the engine and run the engine between 1500 and 2000 RPM until the engine reaches operating temperature.
2. Shut off the engine and allow the springs to cool.
3. After initial run-in, most springs will lose a slight amount of pressure. Re-check and shim up the valve springs if necessary. After the springs are "run in," spring pressure should remain constant until the point of replacement.

CAMS

VALVE TRAIN

PISTONS

RODS

CRANKS

ENGINE KITS

APPAREL